

MERITOR®
an *ArvinMeritor* brand

Technical Bulletin

Procedures and Intervals to Inspect the Wheel Ends and Tighten the Spindle Nuts on Meritor TL Series Trailer Axles with Unitized Wheel Ends

Hazard Alert Messages

Read and observe all Warning and Caution hazard alert messages in this publication. They provide information that can help prevent serious personal injury, damage to components, or both.

WARNING

To prevent serious eye injury, always wear safe eye protection when you perform vehicle maintenance or service.

Park the vehicle on a level surface. Block the wheels to prevent the vehicle from moving. Support the vehicle with safety stands. Do not work under a vehicle supported only by jacks. Jacks can slip and fall over. Serious personal injury and damage to components can result.

ASBESTOS AND NON-ASBESTOS FIBERS WARNING

Some brake linings contain asbestos fibers, a cancer and lung disease hazard. Some brake linings contain non-asbestos fibers, whose long-term effects to health are unknown. You must use caution when you handle both asbestos and non-asbestos materials.

CAUTION

A unitized hub is permanently sealed and lubricated as an assembly. Do not attempt to remove the hub bearings, seals or lubricant. You cannot service or reinstall these components back into a unitized hub. Damage to components can result. Removal of the long-life bearings, seals or lubricants from the Meritor TL model unitized hub will void the warranty.

How to Obtain Additional Maintenance and Warranty Information for TL Series Trailer Axles with Unitized Wheel Ends

Refer to Maintenance Manual MM-0420, Trailer Axles with Unitized Wheel Ends; and Maintenance Manual 14, Trailer Axles. For warranty information, refer to publication SP-95155, Commercial Vehicle Systems Warranty. To access these publications, visit Literature on Demand at arvinmeritor.com.

How to Obtain Parts

Call ArvinMeritor's Commercial Vehicle Aftermarket at 888-725-9355. To obtain Snap-On® tool, part number TTFM932, contact www.snapon.com.

Inspection and Maintenance Intervals by Service Applications

The following is intended as a general guideline for scheduled wheel-end inspections. Note that the recommended frequency of these inspections depends on such service factors as the environment, mileage, speed and loading.

Inspection Intervals

| Application | Description | Intervals |
|-----------------|--|--|
| Linehaul | High mileage, over 60,000 miles per year. On-road service; operated on concrete, asphalt, maintained gravel, crushed rock, hard/packed dirt, or other similar surfaces; moderate grades. More than 30 miles between stopping and starting. | Every 100,000 miles (160 000 km) or 12 months, whichever comes first. Some Examples: Haulers (auto, bulk, grain, etc.), general freight, tanker. |
| General Service | Lower mileage, usually less than 60,000 miles per year. Generally on-road service, with usually less than 10% off-road. Usually 3 miles between stopping and starting. | Every 100,000 miles (160 000 km) or 12 months, whichever comes first. Some Examples: Intermodel chassis service, auto hauler, flatbed. |
| Heavy Service | Moderate mileage, usually less than 60,000 miles per year. On- and off-road service, with usually 10% or more off-road. Moderate to frequent stops and starts, usually up to 10 stops per mile. | At tire replacement. At brake reline. Every 30,000 miles (48 270 km) or 2 months, whichever comes first. Some Examples: Flatbed trailer hauler, log hauling, equipment hauling. |

Scheduled Maintenance

Inspect the wheel end for smooth rotation, movement and seal leaks at each brake reline or regularly scheduled preventive maintenance.

ABS Warning Signal

Inspect the wheel end for smooth rotation, movement and bearing end play if a driver reports that an ABS light has been coming on and ABS diagnostics indicates excessive sensor gap.

Basic Hub Inspection

Perform the following procedure for **each** wheel end on the trailer.

1. Wear safe eye protection.
2. Park the trailer on a level surface. Use a jack to raise the trailer until all of the trailer tires are off the ground. Place safety stands under the trailer frame or axles. Do not use a jack to support the trailer.
3. Rotate the wheel assembly to check for signs of unusual resistance or roughness from the bearing. Listen for a low-pitched grinding sound as you rotate the assembly. Use care to determine whether sounds heard are coming from the bearing and not from the brake components or dust cover.
 - **If unusual resistance or noise is detected:** Replace the hub. Refer to Replace the Hub for correct procedures.

4. Grasp the tire and wheel-end assembly at the 12 and six o'clock positions. Check for vertical and horizontal movement. With your hands, apply approximately 50 lb (23 kg) of force to the assembly. You should not feel or see any looseness or movement. Figure 1.

- **If you feel or see movement at the tire circumference:** Proceed to the Detailed Hub Inspection procedure.
- **If no movement is detected:** Proceed to the Quick Clamp Load and Inspection procedure.

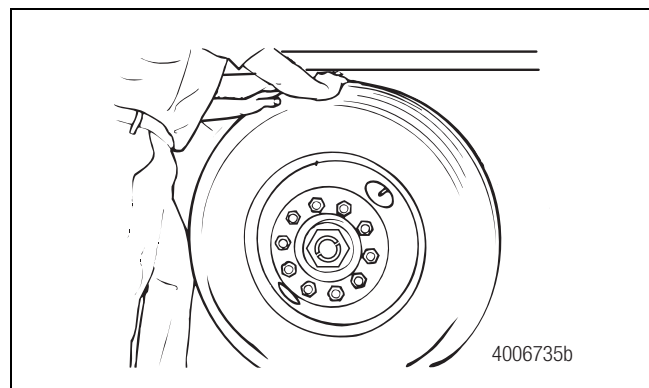

Figure 1

Quick Clamp Load and Inspection Procedure

1. Remove the hubcap.
2. Use a screwdriver to release the stakes from the stake washer flange. Figure 2.

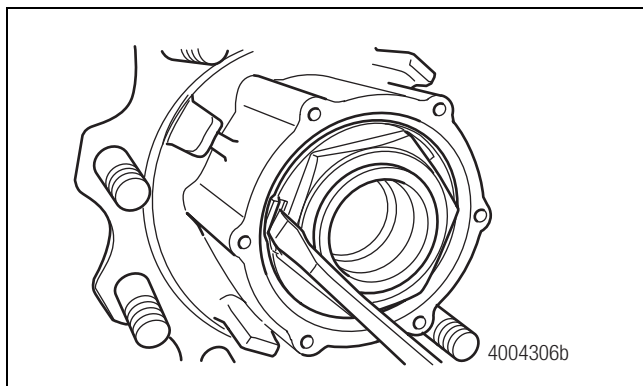



Figure 2

3. Remove spindle nut and stake washer.
4. Install a new stake washer (part number AM21225514).
5. Install new spindle end nut (part number AM21225405) onto the spindle.

⚠ WARNING

You must rotate the hub COUNTERCLOCKWISE while you tighten the spindle nut to the specified torque. If you do not rotate the hub during the tightening procedure, the spindle nut can loosen, and the bearing may not seat correctly, which can cause the wheel to separate from the vehicle during operation. Serious personal injury and damage to components can result.

NOTE: Disregard the torque values embossed into the outer face of the spindle nut. Tighten the nut to the values specified in Step 6 below.

6. Tighten the spindle end nut to **810-850 lb-ft (1100-1150 N•m)** while rotating the wheel and hub COUNTERCLOCKWISE. Do not back off the nut after tightening. Re-clamp and mark the spindle nut position relative to the spindle. For future service, use the marks to show if the nut has rotated. 
7. Rotate the wheel assembly to check for signs of unusual resistance or roughness from the bearing. Listen for a low-pitched grinding sound as you rotate the assembly. Use care to determine whether sounds heard are coming from the bearing and not from the brake components or dust cover.
 - **If unusual resistance or noise is detected:** Replace the hub. Refer to Replace the Hub for correct procedures.

8. Grasp the tire and wheel-end assembly at the 12 and six o'clock positions. Check for vertical and horizontal movement. With your hands, apply approximately 50 lb (23 kg) of force to the assembly. You should not feel or see any looseness or movement. Figure 1.

- **If you feel or see movement at the tire circumference:** Proceed the Detailed Hub Inspection procedure.

NOTE: You must stake the stake washer to the spindle nut in **three** positions.

9. Use a hammer and staking tool (Figure 13) to stake the stake washer to the spindle nut in **three** positions. Bend the washer to the stake profile as shown. Figure 3 and Figure 4.

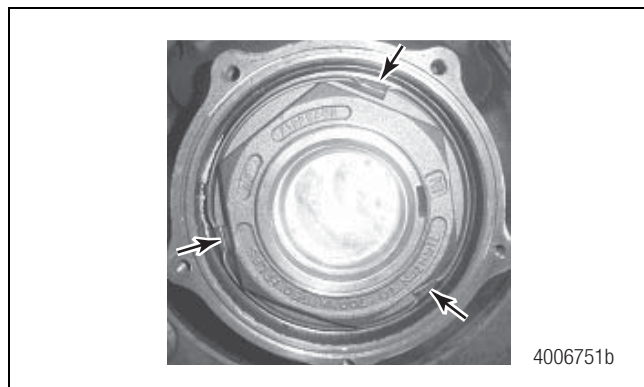

Figure 3

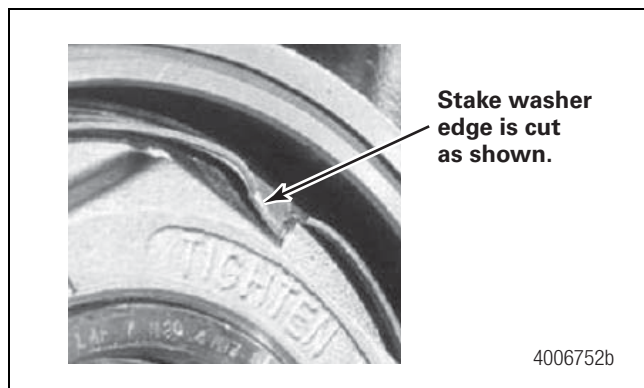



Figure 4

10. Clean the hub end surface and hubcap flange prior to reassembly of the hubcap.
11. Install the hubcap with a new gasket (part number 2208-B-1172). Install new hubcap capscrews. Tighten the hubcap capscrews in a crisscross pattern to 15-30 lb-ft (20-40 N•m). 

Detailed Hub Inspection

1. Follow the wheel manufacturer's instructions to remove the tire, wheel assembly and brake drum.
2. If necessary, remove the hubcap.
 - **If this is not the first inspection:** Check the mark on the spindle nut and spindle to see if the nut has moved.
 - **If the mark has moved, then the nut was not previously tightened enough:** Clean the threads.
3. Attach the magnetic base of the dial indicator to the spindle. Touch the dial indicator stem to the hubcap mounting surface. Figure 5.

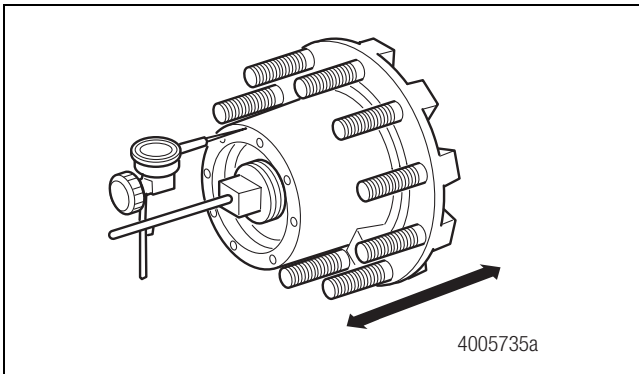

Figure 5

4. Set the dial indicator to ZERO. Do not rotate the wheel end. Place your hands at the nine and three o'clock positions.
5. Push the unitized wheel end straight IN. Note the reading. Then pull the wheel end straight OUT. Note the reading.
 - **If the total movement of the dial indicator is less than 0.003-inch (0.08 mm):** Follow instructions 2 through 11 in the Quick Clamp and Load Inspection procedure.
 - **If the total movement is 0.003-inch (0.08 mm) or greater:** Proceed to the Thread Inspection procedure.

Thread Inspection

Perform the following procedure for each wheel end on the trailer with end play at the hub greater than 0.003-inch (0.08 mm) or wheel movement greater than 0.04-inch (1 mm).

1. Use a screwdriver to release the stakes from the stake washer flange. Figure 6.

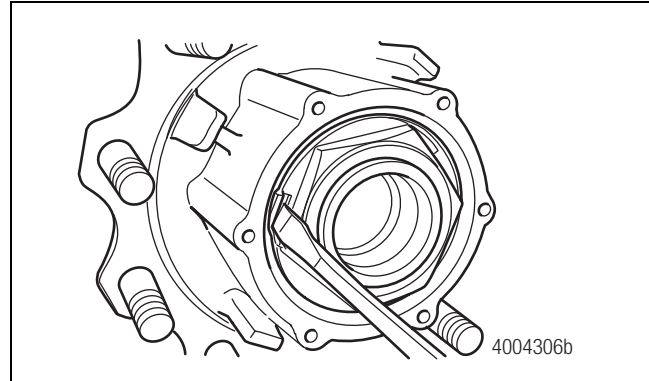

Figure 6

2. Remove the spindle nut from the spindle end. Figure 7.

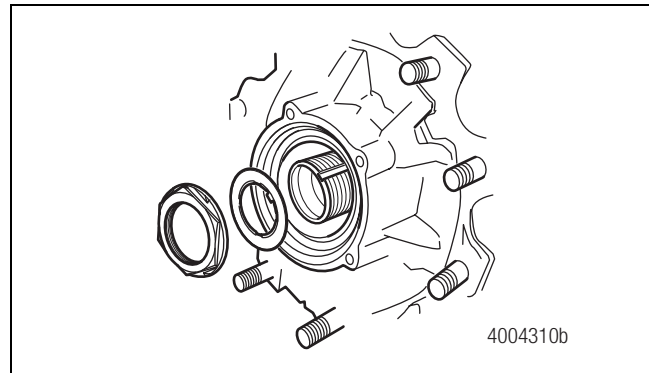

Figure 7

3. Check the spindle threads. Figure 8.
 - **If the threads are not free running, and a limit of two threads are damaged:** Repair the threads with a thread file (Snap-On® tool, part number TTFM932, or equivalent).
 - **If there are more than two threads damaged:** Replace the axle beam. Refer to Maintenance Manual 14 for the procedures.

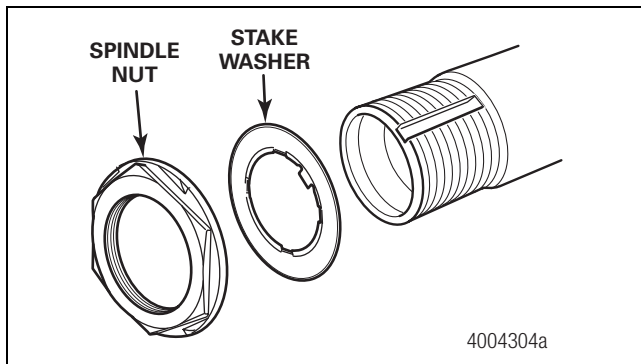

Figure 8

4. Clean the spindle threads and nut threads.
5. Install a new stake washer (part number AM21225514) onto the spindle.
6. Install the spindle end nut (part number AM21225405) onto the spindle.

⚠ WARNING

You must rotate the hub **COUNTERCLOCKWISE** while you tighten the spindle nut to the specified torque. If you do not rotate the hub during the tightening procedure, the spindle nut can loosen, and the bearing may not seat correctly, which can cause the wheel to separate from the vehicle during operation. Serious personal injury and damage to components can result.

NOTE: Disregard the torque values embossed into the outer face of the spindle nut. Tighten the nut to the values specified in Step 7 below.

7. Tighten the spindle end nut to 810-850 lb-ft (1100-1150 N•m) while rotating the wheel and hub in a **COUNTERCLOCKWISE** direction. Do not back off the nut after tightening. Mark the nut location relative to the spindle. Figure 9. **🔧**

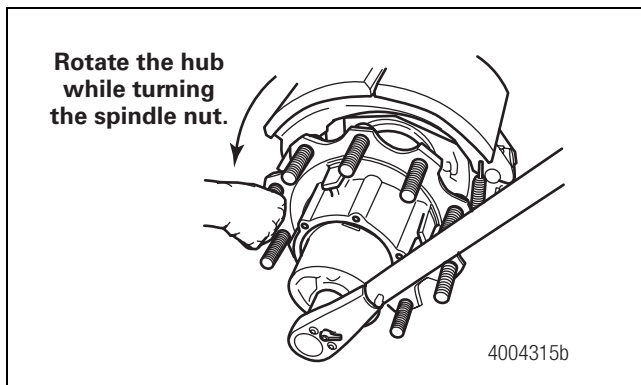

Figure 9

8. Check for wheel-end movement to ensure the wheel end rotates freely as described in the inspection procedure. Verify end play is less than 0.003-inch (0.08 mm) by following Steps 3, 4 and 5 of the Detailed Hub Inspection procedure.

- **If end play is greater than 0.003-inch (0.08 mm):**
Replace the hub. Refer to Replace the Hub for correct procedures.

NOTE: You must stake the stake washer to the spindle nut in **three** positions.

9. Use a hammer and staking tool (Figure 13) to stake the stake washer to the spindle nut in **three** positions. Figure 10 and Figure 11.

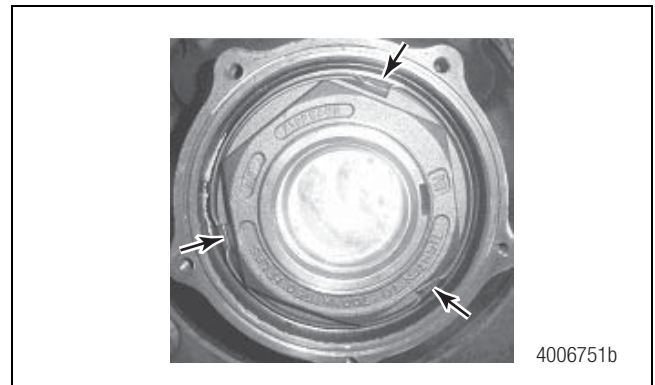

Figure 10

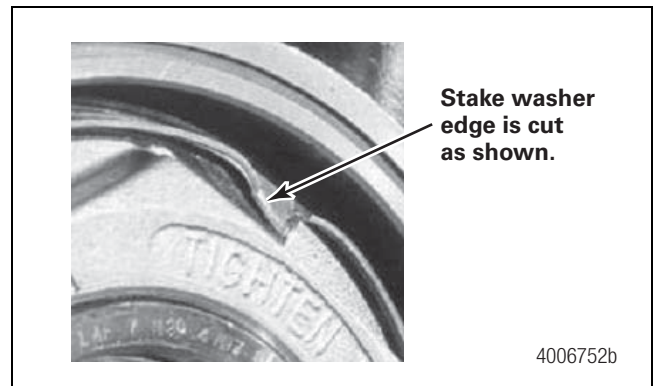

Figure 11

10. Clean the hub end surface and hubcap flange prior to reassembly of the hubcap.
11. Install the hubcap with a new gasket (part number 2208-B-1172). Install new hubcap capscrews. Tighten the hubcap capscrews in a crisscross pattern to 15-30 lb-ft (20-40 N•m). **🔧**

Replace the Hub

Refer to Maintenance Manual MM-0420 for correct procedures.

Contact ArvinMeritor's Commercial Vehicle Aftermarket at 888-725-9355 for the correct hub replacement part number.

NOTE: Previous versions of TL hubs may or may not have an O-ring on the inboard side of the hub. All replacement hubs will include an O-ring. This O-ring must be installed with the replacement hub regardless of previous hub arrangement.

1. Ensure the O-ring (part number AM1205Q2747) between the bearing cartridge and the spindle shoulder is inserted into the groove and in place when the hub is installed. Figure 12.

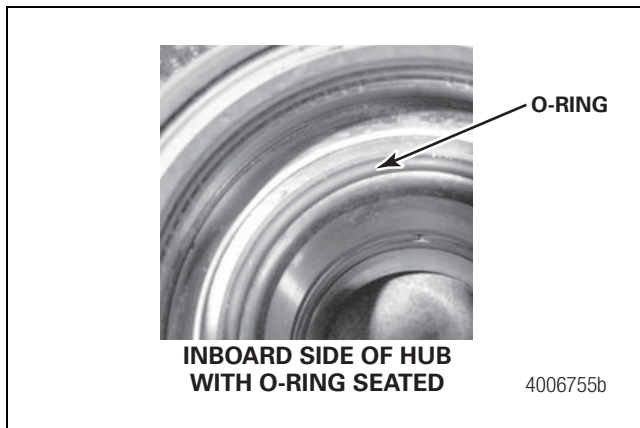

Figure 12

2. Check the spindle to ensure there is NOT an extra O-ring.

Staking Service Tool

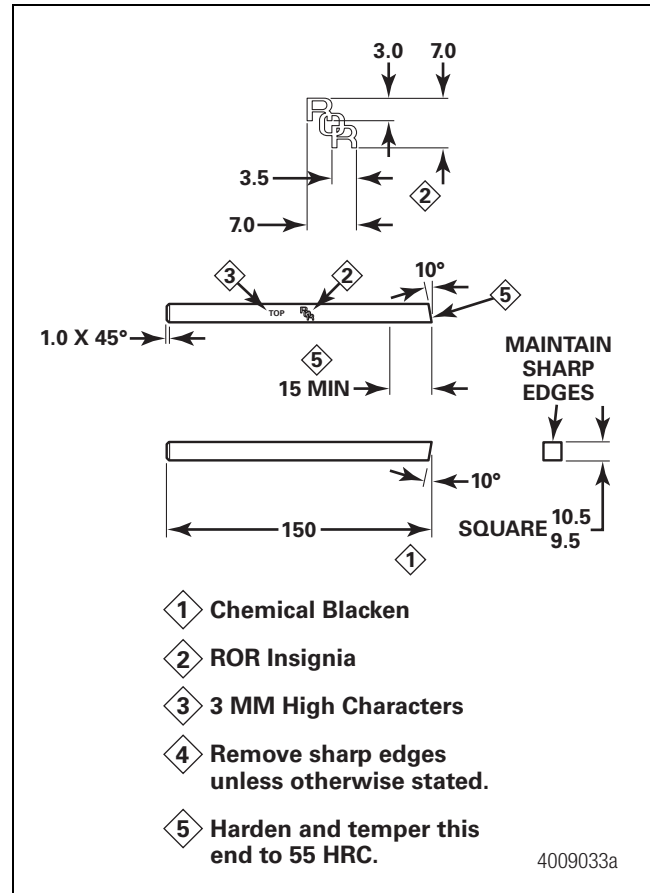

Figure 13

ArvinMeritor™

Meritor Heavy Vehicle Systems, LLC
 2135 West Maple Road
 Troy, MI 48084 USA
 866-OnTrac1 (668-7221)
 arvinmeritor.com

Information contained in this publication was in effect at the time the publication was approved for printing and is subject to change without notice or liability. Meritor Heavy Vehicle Systems, LLC, reserves the right to revise the information presented or to discontinue the production of parts described at any time.

Copyright 2011
 ArvinMeritor, Inc.
 All Rights Reserved

Printed in USA

TP-0860
 Revised 02-11
 (16579)