



March 5<sup>th</sup>, 2014

Dear Cottrell Equipment Owner:

Please find enclosed Service Bulletin #SB015 which contains instructions for modifying the post behind the cab on the headramp.

Our records indicate that you are the current owner of a Cottrell Headramp (or multiple headramps) that may be affected by Service Bulletin # SB015. The serial number(s) of your headramp(s) are indicated on the enclosed sheet. If you no longer own the headramp(s) identified on the enclosed sheet, please indicate the new owner in the enclosure and return it to us at the address below:

Cottrell, Inc.  
2125 Candler Road  
Gainesville, GA 30507  
Attn: Technical Publications

The Cottrell Service Center (800-827-0132), Authorized Cottrell Dealers, or any Authorized Cottrell Warranty Repair Facility may perform the modification for you. You can access a list of these facilities at [www.cottrelltrailers.com](http://www.cottrelltrailers.com) under Service Centers.

Cottrell will reimburse a maximum of 8.0 hours of labor per headramp modified for the work associated with this Service Bulletin. Requests for reimbursement can be submitted with receipt to the above address or handled directly through the repair facility under normal procedures.

Please read Service Bulletin #SB015 and have the modification completed as soon as possible according to the instructions provided. This Service Bulletin shall remain open for one (1) calendar year.

Should you have any questions concerning this bulletin, please contact Cottrell or your Authorized Cottrell Dealer.

Sincerely,  
Chris Nish / Warranty Coordinator  
800-827-0132 Ext. 313



March 5<sup>th</sup> 2014

Service Bulletin #SB015

**Subject:** 3.5 CAR 2<sup>nd</sup> Post Modification

**Models Affected:** New, Listed 3.5 CAR cylinder/strap headramps

**Instructions:**

1. See enclosed drawing.
2. Remove hydraulic and electrical components from posts.
3. Gouge out and weld cracks.
4. Weld reinforcement plates as shown.
5. Replace hydraulic and electrical components in posts.
6. Touch up reworked areas.

ECO NUMBER	ZONE	REV	REVISION-DESCRIPTION	DATE	BY	CHECKED
C16086						

- NOTES:
1. GOUGE OUT AND WELD UP CRACKS.
  2. WELD PARTS AS SHOWN.
  3. WELD 50% EXCEPT WHERE NOTED.
  4. DOWNHILL WELDS PERMITTED.
  5. PLATES ON SOME UNITS WILL BE INSTALLED ON THE REAR SIDE OF THE POST.

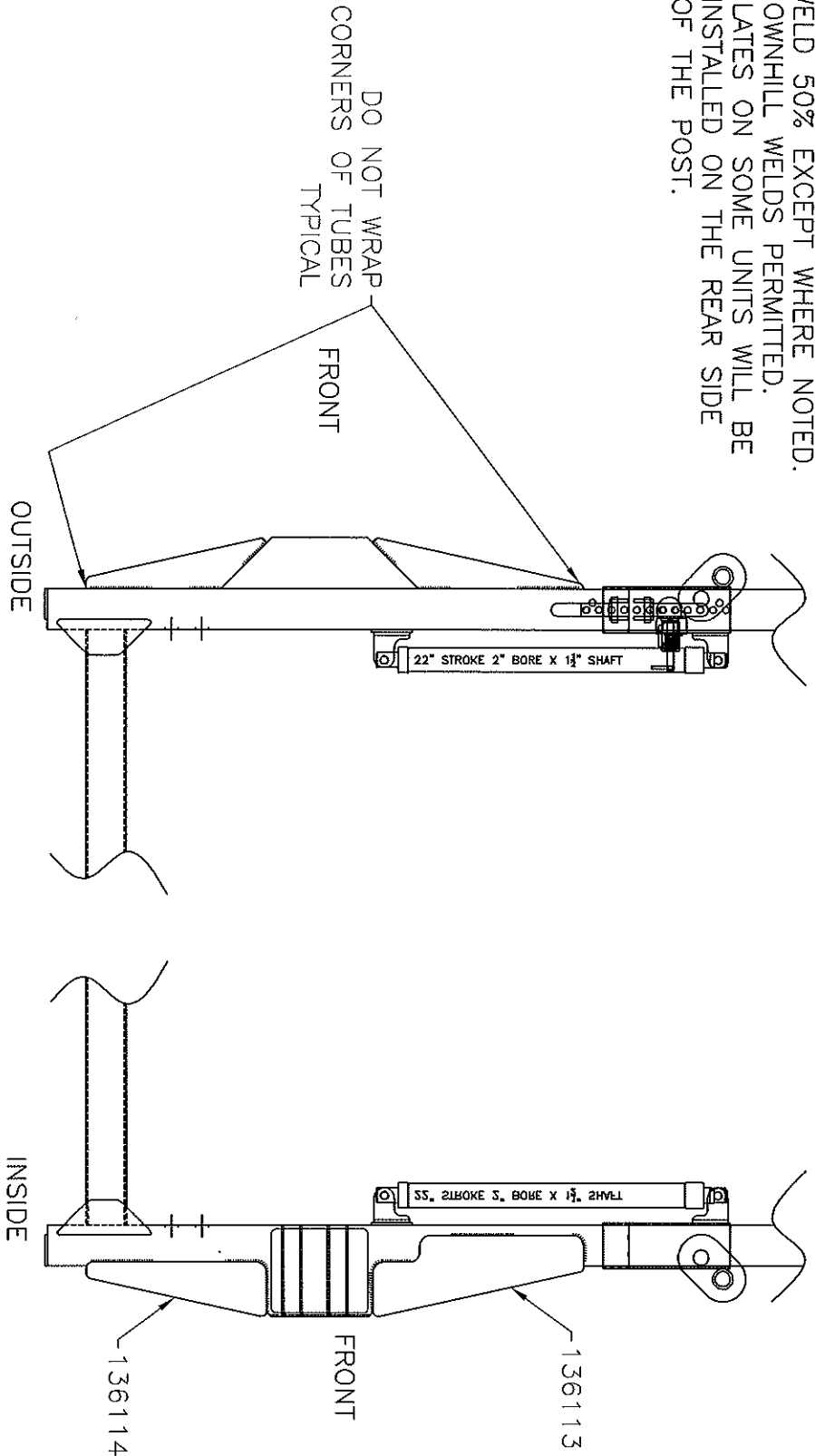

DO NOT WRAP  
CORNERS OF TUBES  
TYPICAL



THE INFORMATION CONTAINED IN THIS DRAWING IS THE SOLE PROPERTY OF COTTRELL, INC. ANY REPRODUCTION OR USE OF THIS INFORMATION WITHOUT THE WRITTEN PERMISSION OF COTTRELL INC. IS PROHIBITED.

STANDARD TOLERANCES UNLESS OTHERWISE NOTED  
 DECIMALS: .005  
 FRACTIONS: 1/16  
 DIMENSIONS: .000  
 .001  
 .010

ORIG BY: DST	PROG. NO. —	MATERIAL 0006	MATERIAL DESCRIPTION PLT .25 DOMEX 100XF	SIMILAR TO —	SCALE 1:1
ORIG DATE: 7/12/2013	PROG. BY —	MAKE FROM —	PART YIELD —	—	SIZE A
CHK BY: —	PROG. DATE —	FINISH —	WEIGHT —	DWG. NO. —	REV IR
CHK DATE: —	TITLE KIT 2ND POST REINFORCEMENT 3.5 CAR HR 136108	PART NO. —	—	—	—